

# Juniper M10 QoS Capabilities

Sven Ubik ([ubik@cesnet.cz](mailto:ubik@cesnet.cz))

28.12.2001

## 1 Introduction

This is a summary of our assesment of QoS capabilities of the Juniper M10 router. We performed this assesment as a part of our QoS in IP project<sup>1</sup>. This is not a scientific test, just our practical view based on our experience with QoS-related topics. We are gathering information about current possibilities of network QoS implementations available with various equipment and technologies. We are primarily concerned with possibilities related to the implementation of the Premium IP<sup>2</sup> service proposed for the European Geant<sup>3</sup> network. We did not tested other features of the router (such as routing protocols, etc.), although we add a few remarks regarding practical use of the router.

Our current network is primarily based on Cisco routers. The Juniper M10 router can be classified as belonging to the same category as a Cisco 7500 series router in terms of available interfaces, routing power and places where it can be used a network. Therefore, we will compare Juniper M10 characteristics with the Cisco 7500.

At the time when we performed our experiments, the latest router operating system release available was JUNOS 5.0. Recently, a new release JUNOS 5.1 became available, with QoS support significantly redesigned. When comparing the QoS-related features, we will consider the latest release JUNOS 5.1. When describing our experiment results, we will mention the differences between the current release and the release that we used.

Measurements of QoS parameters (throughput, delay, etc.) were performed using our own measurement system [qosplot] based on RUDE/CRUDE<sup>4</sup> packet generation/capture utilities.

---

<sup>1</sup><http://www.cesnet.cz/english/project/qosip>

<sup>2</sup><http://www.dante.net/sequin/mauro-tnc01/index.html>

<sup>3</sup><http://www.geant.net>

<sup>4</sup><http://www.atm.tut.fi>

## 2 Overview of QoS-related features

Table 1 summarizes the QoS-related features available on Juniper M10 and Cisco 7500 routers. We selected the features useful for a diffserv-based architecture.

<i>Feature</i>	<i>Juniper M10</i>	<i>Cisco 7500</i>
Metering	Simple token bucket	Simple and dual token bucket (srTCM)
Classification	input interface, IP precedence, MPLS exp. bits, IEEE 802.1Q service	same as Juniper with access lists in place of filters, plus source and destination MAC addresses, minus IEEE 802.1Q service
Marking	IP priority, DSCP, MPLS exp. bits, IEEE 802.1Q service	same as Juniper, minus IEEE 802.1Q service
Priority Queueing	Yes (two levels)	Yes (two levels)
Bandwidth sharing	WRR	WFQ
Congestion prevention	WRED	WRED
Traffic shaping	Yes (see notes)	Yes

**Table 1:** Comparison of QoS-related features on Juniper M10 and Cisco 7500

Notes:

- **Classification:** both platforms offer wide range of classification possibilities particularly owing to references to filters on Juniper or functionally equivalent access lists on Cisco. Cisco adds classification based on source and destination MAC addresses, but Juniper adds classification based on IEEE 802.1Q service, which seems to be more useful allowing integration of level-3 QoS in backbone and level-2 QoS in local network.
- **Marking:** Juniper again includes support for setting the IEEE 802.1Q service, which is useful for level-3 and level-2 QoS integration. Marking in Juniper is bound to queues, to which packets are sorted as a result of classification. One marking for one queue can be specified. Cisco offers slightly more flexibility with hierarchical service policies, where marking can be specified independently of sorting packets into queues.
- **Bandwidth sharing:** advantage of WRR (Juniper) is lower processor load, whereas advantage of WFQ (Cisco) is more accurate approximation of GPS (Generalized Processor Sharing) resulting in a fair treatment of streams with packets of different sizes. In practice, the unfairness introduced by

WRR is not significant and lower processor load probably outweighs this disadvantage.

- Traffic shaping: currently, it seems that traffic shaping is available only on SONET and ATM interfaces. Specifically, it is probably not available on Fast Ethernet and Gigabit Ethernet interfaces.

### 3 Experiment configuration

The hardware configuration of the experiment is shown in Fig. 1. The key part of the router software configuration is shown below. The software configuration applies to JUNOS 5.0 release. The newer JUNOS 5.1 release uses different configuration.

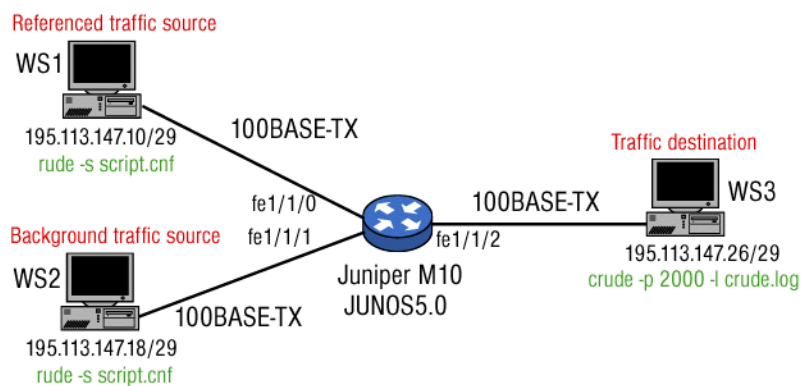

**Figure 1:** Hardware configuration of the experiment

```
class-of-service {
  input {
    precedence-map map1 {
      bits 000 queue 0;
      bits 001 queue 1;
      . . .
    }
  }
  fpc 1 {
    precedence-map map1;
  }
  interfaces {
    fe-1/0/0 {
      inet-precedence-map;
    }
  }
}
```

```

}
output {
  interfaces {
    fe-1/0/1 {
      weighted-round-robin {
        output-queue 0 weight 50;
        output-queue 1 weight 50;
      }
    }
  }
}
}
}

```

## 4 Scheduling

The new JUNOS 5.1 release supports Priority Queueing (PQ). The JUNOS 5.0 release did not support PQ. Therefore, we tested only bandwidth sharing, which is implemented by the WRR algorithm in Juniper routers. We tried the WRR functionality by sending a testing stream of 80 Mb/s for 15 seconds with a background stream of 80 Mb/s added at 5 seconds lasting for 5 seconds. That is both streams competed for the Fast Ethernet bandwidth in the period from 5 to 10 seconds. Both streams consisted of 1500-byte packets.

### 4.1 FIFO

Measured throughput of both streams without WRR enabled (both streams were served by one queue) is shown in Fig. 2. As indicated, the two streams did not share the line bandwidth equally. Throughput experienced a strange temporal effect. We repeated this test for a longer period of time to see how throughput develops over the time. Measured throughput for the test expanded to 30 seconds is shown in Fig. 3. As indicated, the throughput of each of the two streams fluctuated in a complex pattern. The reason of this behaviour is not clear. Measured one-way delay of the referenced stream is shown in Fig. 4.

### 4.2 WRR

Measured throughput of both streams with WRR enabled (each stream was given 50 Mb/s) is shown in Fig. 5. Measured throughput with WRR enabled with the background stream consisting of 256-byte packets is shown in Fig. 6. As indicated, throughput of the 256-byte stream was lower than throughput of the 1500-byte stream although both streams were allocated the same share of the link. The reason is in the unfairness of the WRR algorithm that gives more

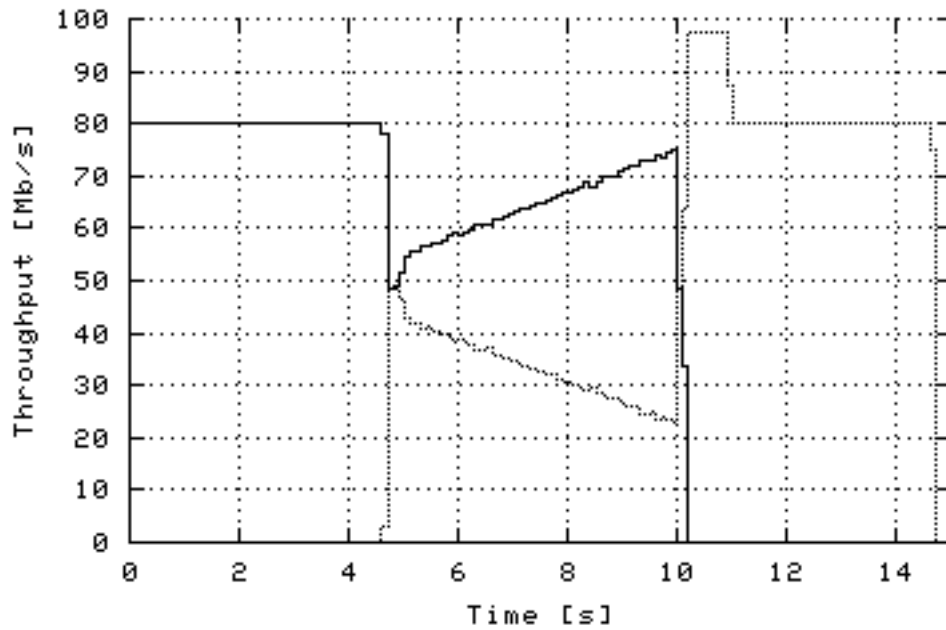

**Figure 2:** Throughput without WRR

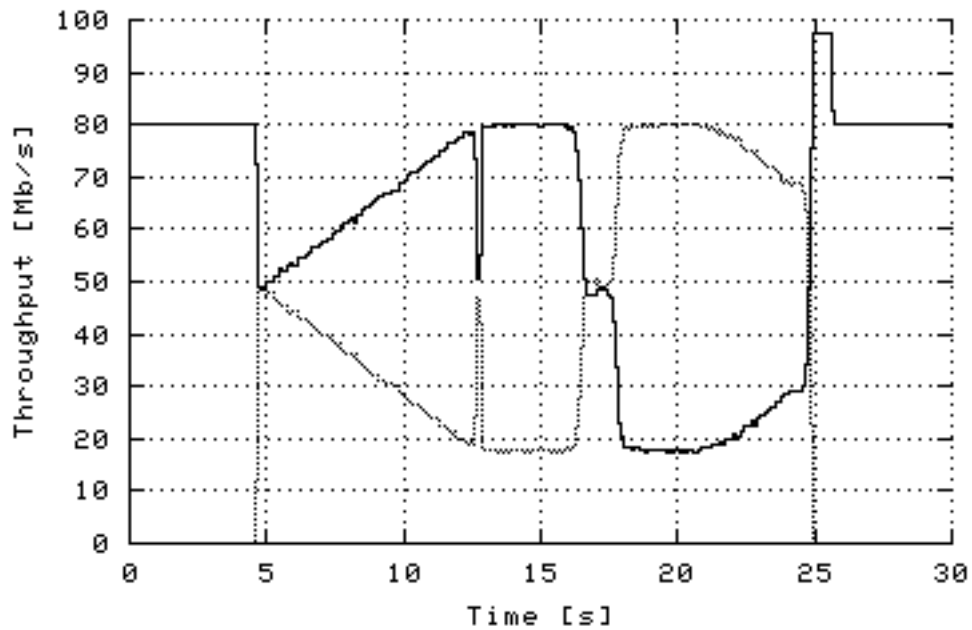

**Figure 3:** Throughput without WRR, test expanded to 30s

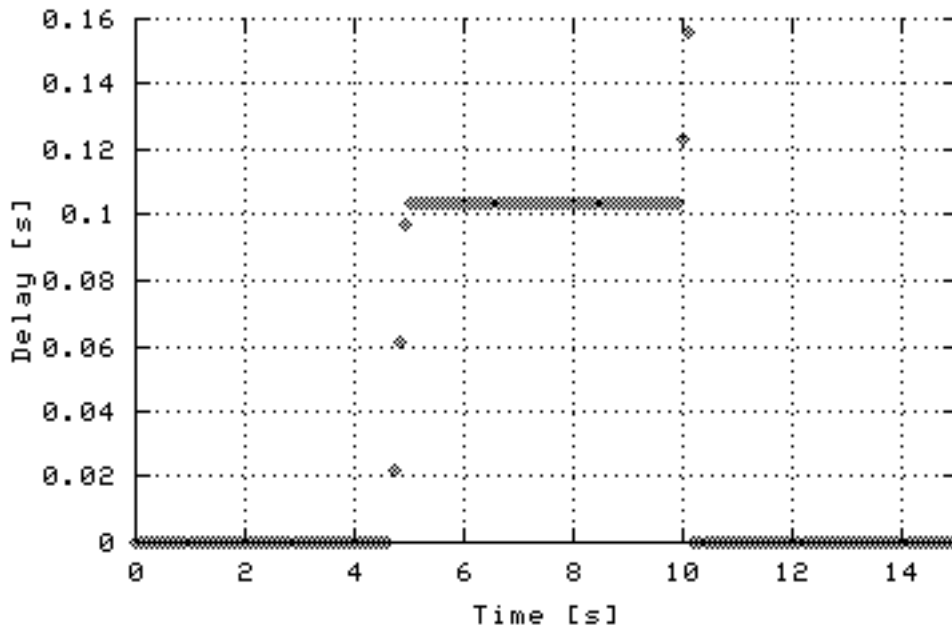
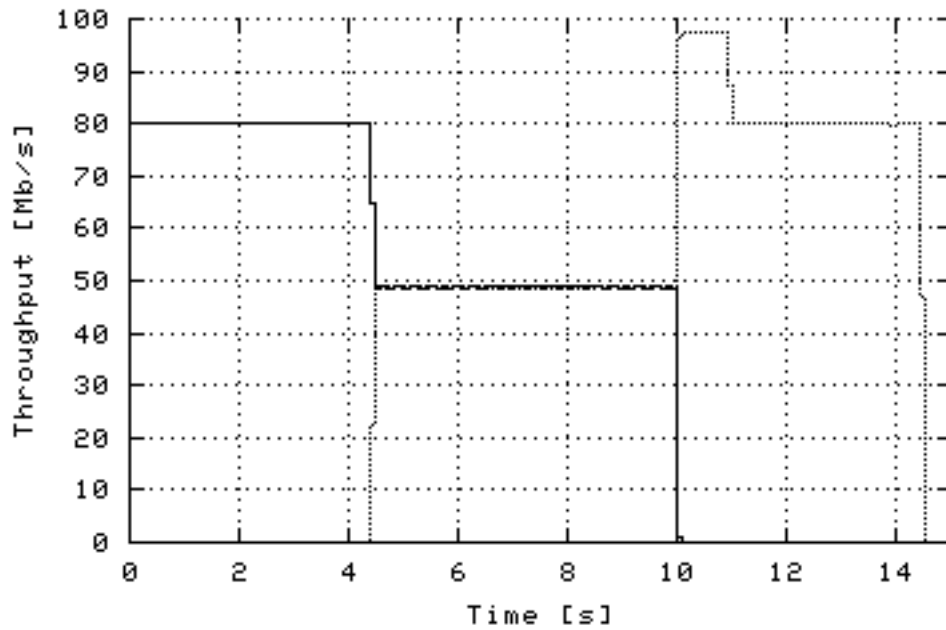

**Figure 4:** One-way delay without WRR

bandwidth to streams with longer packets. Measured one-way delay of the referenced stream is shown in Fig. 7. As indicated, WRR significantly reduces the increase of delay when background stream is applied.

## 5 XML API

Juniper routers provide an API that allows to send any configuration commands to the router over the network and receive the response produced by the router. The API is specified as an XML document type. The commands and the response are structured as XML documents and can be sent in a secure way using SSH. Furthermore, as Juniper boxes run a variant of a BSD operating system, users can execute their own processes on the router, which can communicate over the network by any protocol. These features make it possible to implement a broad class of signaling. This can be used, for example, for the communication between a bandwidth broker and edge routers of a diffserv domain. It is a welcomed improvement over Cisco routers, which are completely closed boxes.



**Figure 5:** Throughput with WRR

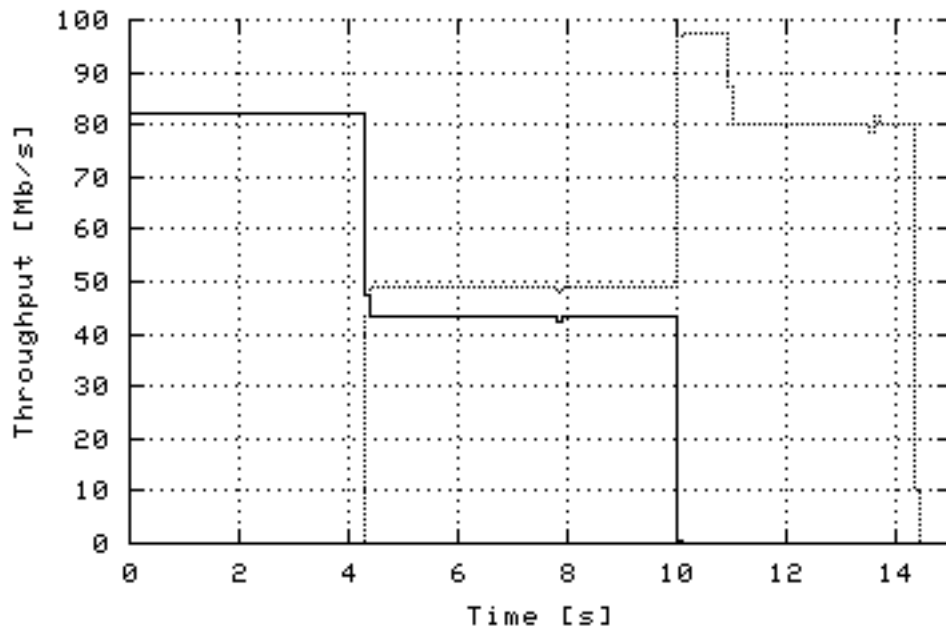

**Figure 6:** Throughput with WRR with background stream of 256-byte packets

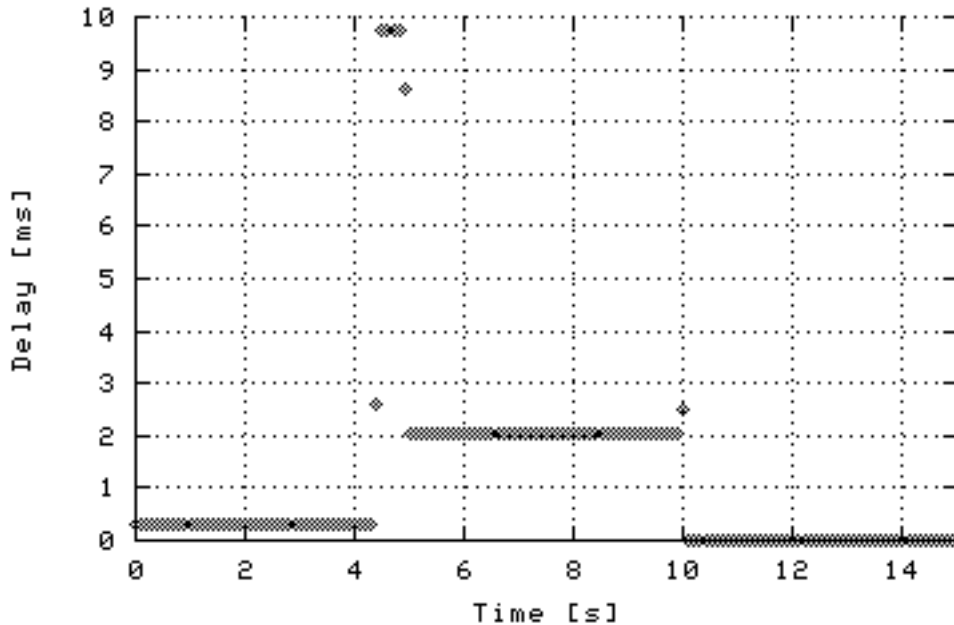

Figure 7: One-way delay with WRR

## 6 Acknowledgements

We would like to thank to the Unient Communications<sup>5</sup> company for a loan of the Juniper M10 router and particularly to Mr. Jan Staniček who provided us with expertise on router configuration.

## 7 Conclusion

We were pleased by a few practical points. For instance, when you press a Tab key to complete a word when typing a command in CLI, the word is completed on the line where you are. That is the screen does not scroll up as on Cisco routers, which is completely useless and causes often important information on the screen to disappear. The JUNOS documentation also appears to be more compact than hundreds of scattered files of Cisco IOS documentation. On the other hand, certain topics are not described in sufficient detail to fully understand them and to make corresponding configuration tasks without problems.

Juniper M10 is roughly comparable in routing power to Cisco 7500 with VIP-based adapters. It lacks traffic shaping on Fast Ethernet and Gigabit Ethernet interfaces, but provides both classification and marking based on IEEE 802.1Q service, which is useful for integration of level-3 and level-2 QoS implementation.

<sup>5</sup><http://www.unient.cz>

This feature first appeared in the new JUNOS 5.1 release and we did not tested it. Juniper also offers an XML API enabling implementation of signaling protocols. We did only basic functionality experiments with the XML API.

When considering the use of Juniper routers in a large network, we suggest to check compatibility of routing protocols, MPLS and all other required features with the already installed base of equipment as well as timely corrections of possible problems in JUNOS releases.

## References

- [qosplot] Sven Ubik, Vladimír Smotlacha (Cesnet), Sampo Saaristo (Technical University of Technology), Juha Laine (Soon Communications): Low-Cost Precise QoS Measurement Tool, Cesnet Technical Report 7/2001<sup>6</sup>.

---

<sup>6</sup><http://staff.cesnet.cz/ubik/publications/index.html#qosplot>